

ASSEMBLY INSTRUCTION

PLEASE READ BEFORE ASSEMBLING!

Tip #1: Make sure you've taken all the pieces and hardware out of its packaging before discarding the box.

Tip #2: Using page 2 and/or page 3 of instruction manual make sure all pieces and hardware are accounted for.

ITEM#:171982

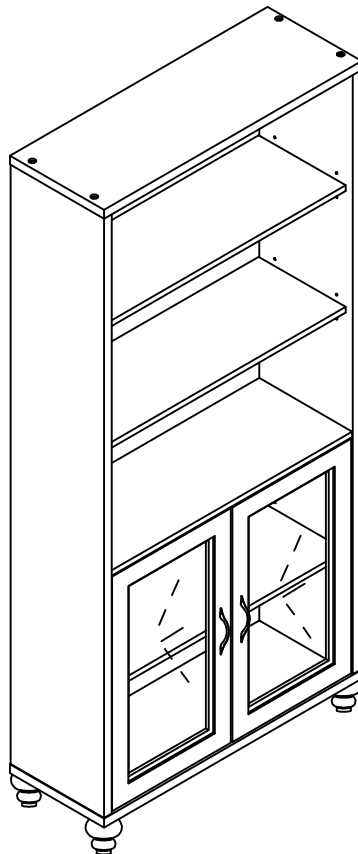

PARTS IDENTIFICATION



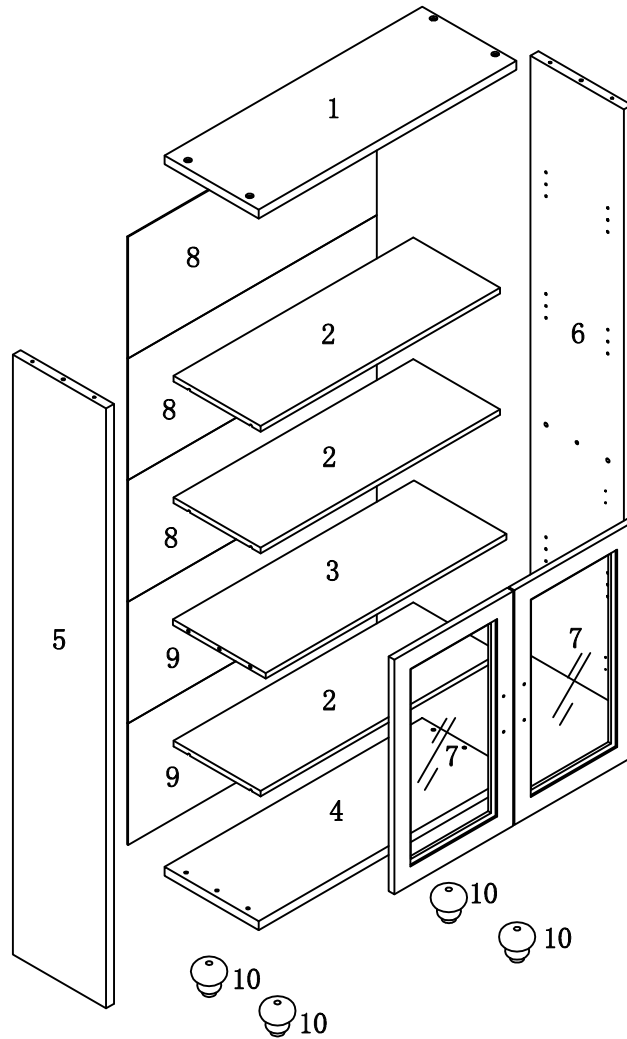















ITEM#:171982



(1)	1pc	(6)	1pc
(2)	3pcs	(7)	2pcs
(3)	1pc	(8)	3pcs
(4)	1pc	(9)	2pcs
(5)	1pc	(10)	4pcs

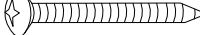
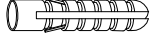

HARDWARE IDENTIFICATION

ITEM#:171982

A		L29	4PCS
B		Φ 15	4PCS
C		Φ 8x25	6PCS
D		Φ 7x48	8PCS
E		Φ 8x16x2	12PCS
F		Φ 5x10	12PCS
G		96-122	2PCS
H		M4x20	4PCS
I		301C	4PCS
J		Φ 4x16	16PCS
K		5MM	1PC
L		M8x40	4PCS
M		Φ 22 (RC)	4PCS
N			52PCS
O		197×5×1	1PC
P		ø4×25	1PC
Q		ø5×40	1PC
R		ø8×40	1PC
S		12×12×1	2PCS
T		Glue: For securing please apply to wood dowel first before inserting into panel	1PC

HARDWARE IDENTIFICATION

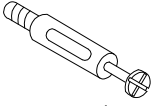
ITEM#:171982

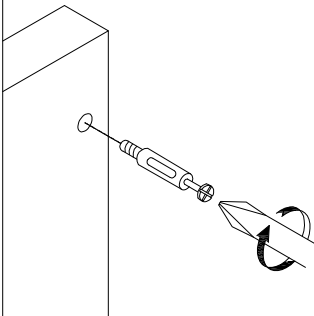
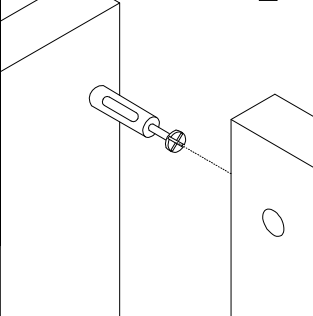
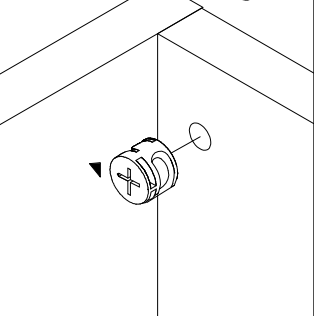
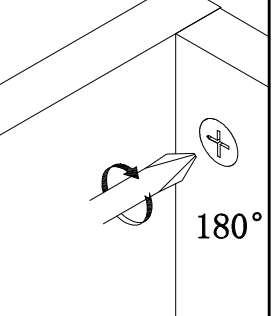
HOW TO	1	2	3	4
 Cam Bolt  Cam Lock				
	1. Screw Cam Bolt into panel.	2. Insert Cam Bolt into bolt hole of joining panel.	3. Insert Cam Lock. arrow facing bolt.	4. Gently turn Cam Lock clockwise to lock position.

STEP 1

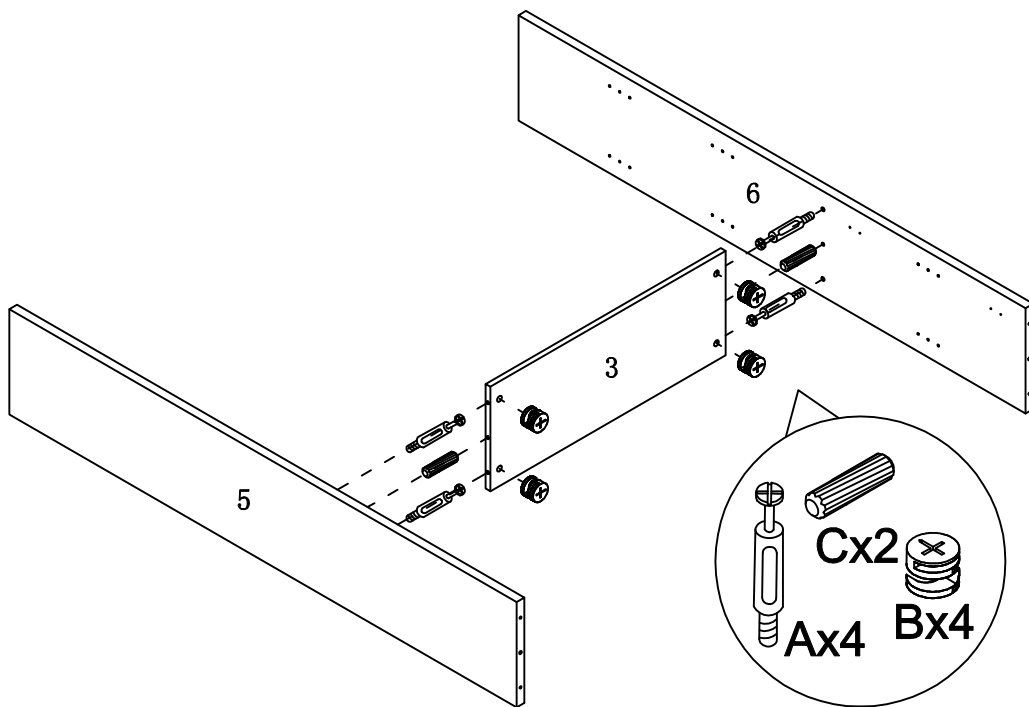

HARDWARE IDENTIFICATION

ITEM#:171982

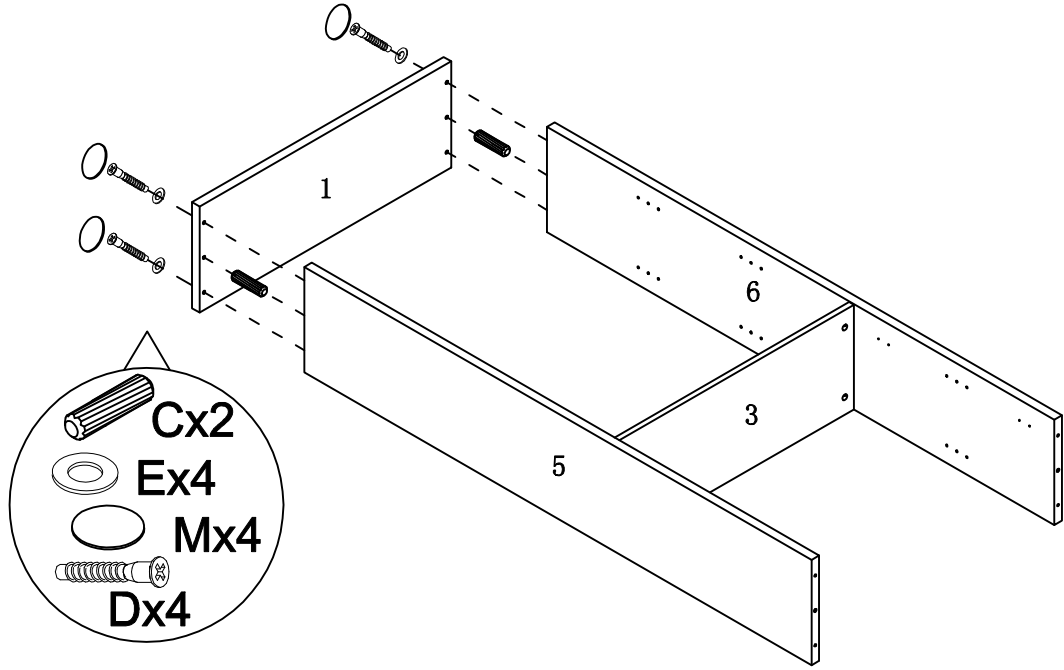

STEP2

STEP3

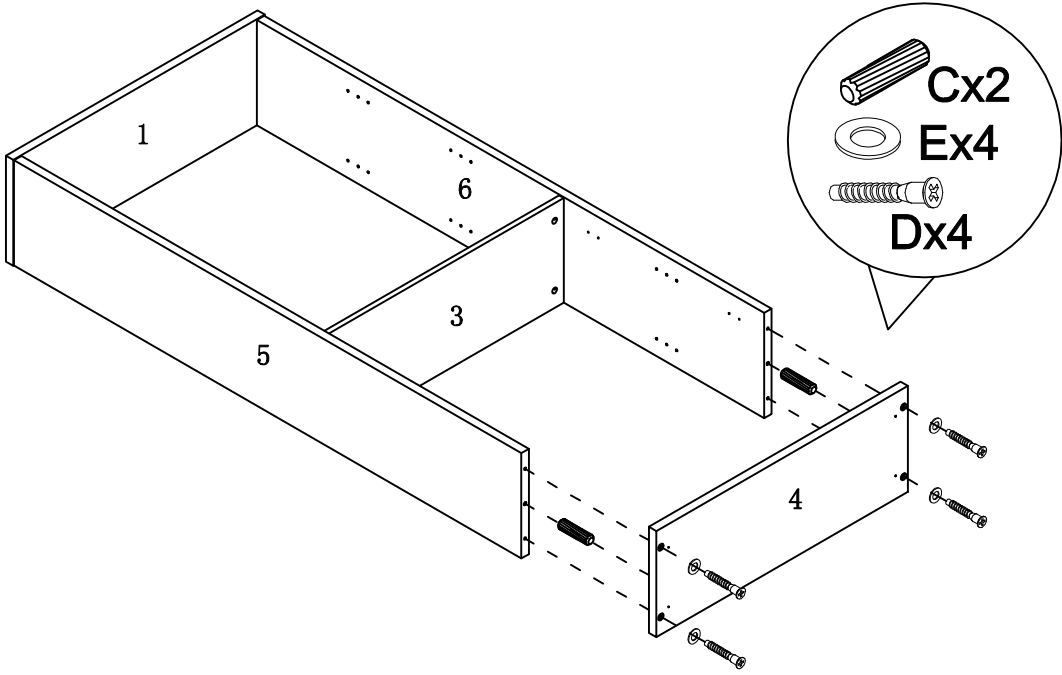

HARDWARE IDENTIFICATION

ITEM#:171982

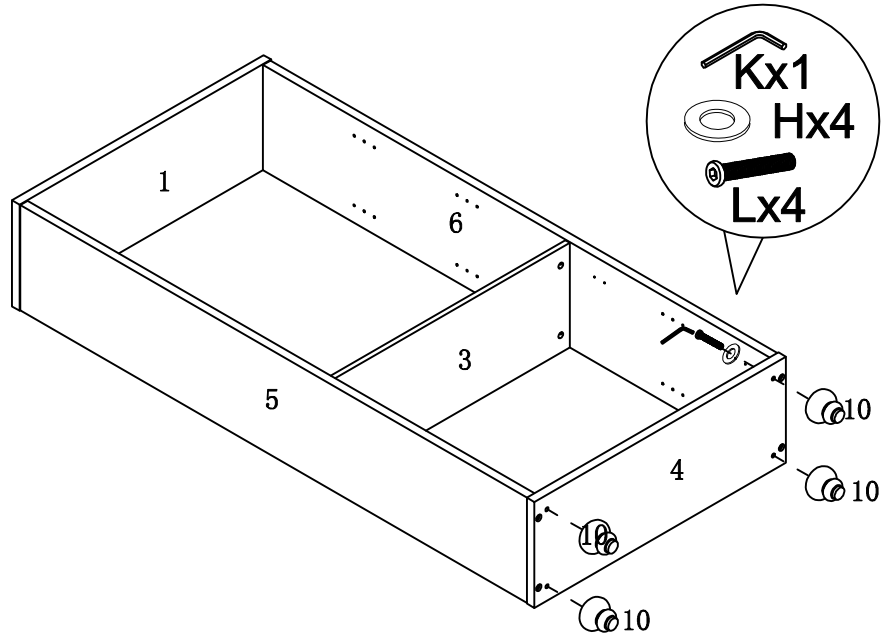

STEP4

STEP5

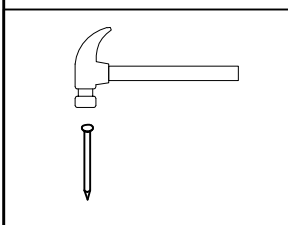
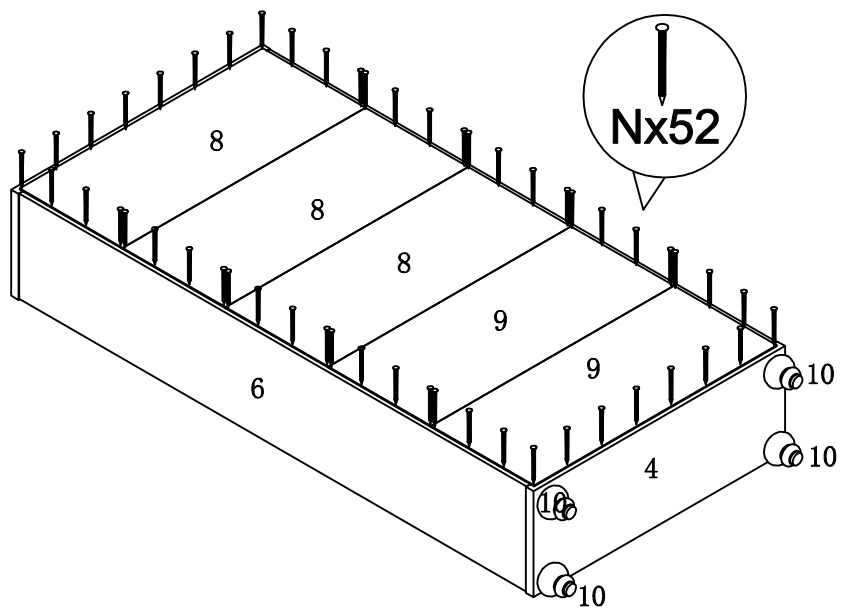

HARDWARE IDENTIFICATION

ITEM#:171982

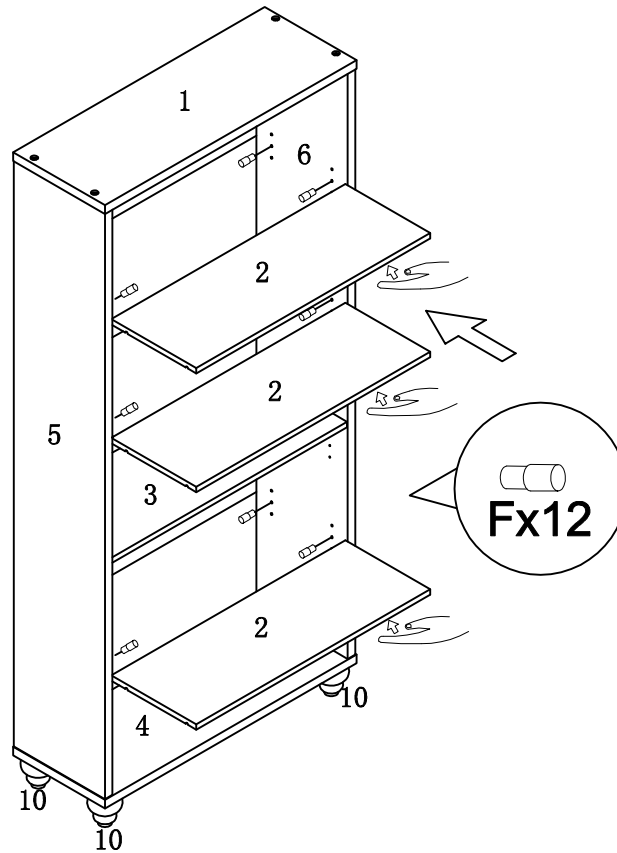

STEP6

STEP7

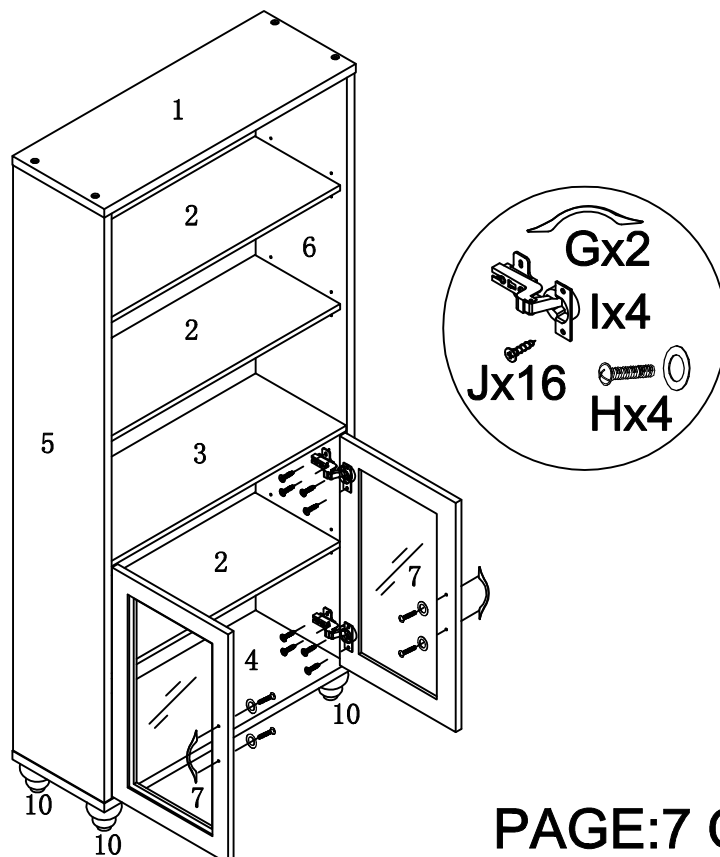

PAGE:7 OF 7

To adjust the door in or out, loosen this screw and push the door further in or push further out then retighten screws.

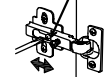

To adjust the door vertically, loosen the top and bottom screws, push the door up or down as necessary, then retighten screws.



To adjust the door left/right, turn this screw clockwise to move this corner of the door toward the frame, or counterclockwise to move door away from the frame.

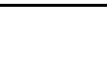

ANTI-TIPPING STRAP INSTRUCTION

HARDWARE (INCLUDED) :

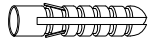

DRYWALL ANCHOR $\phi 8 \times 40$ X 1PC

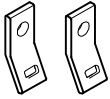

METAL BRACKETS $12 \times 12 \times 1$ X 2PCS



DRYWALL SCREW $\phi 5 \times 40$ X 1PC



STRAP $197 \times 5 \times 1$ X 1PC



FLATHEAD SCREW $\phi 4 \times 25$ X 1PC

TOOLS NEEDED (NOT INCLUDED) :

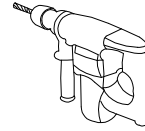

DRILL & DRILL BIT



LIGHT HAMMER

Note: Hardware included only compatible with standard drywalls.

STEP 1

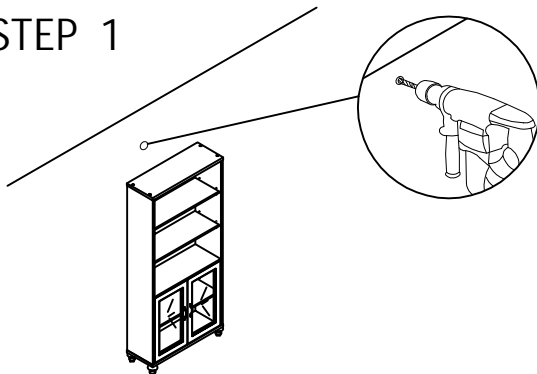

1. Find spot on wall 1" below top of item.
2. Using a drill bit slightly thinner than anchor, drill hole into drywall.

STEP 2

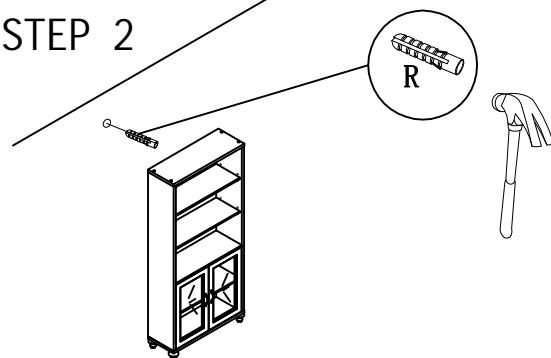

1. Use a light hammer to tap anchor into hole.
2. Anchor should fit snugly. If hole is too small, drill again to increase hole size. Do not force anchor into wall.

STEP 3

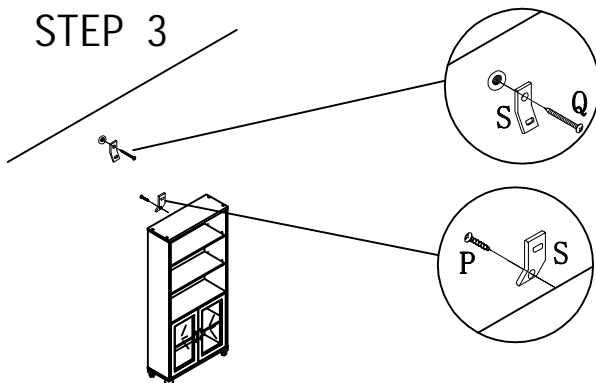

1. Insert drywall screw into metal bracket and into drywall anchor.
2. Insert flathead screw into second metal bracket and into back of item, along top edge.

STEP 4

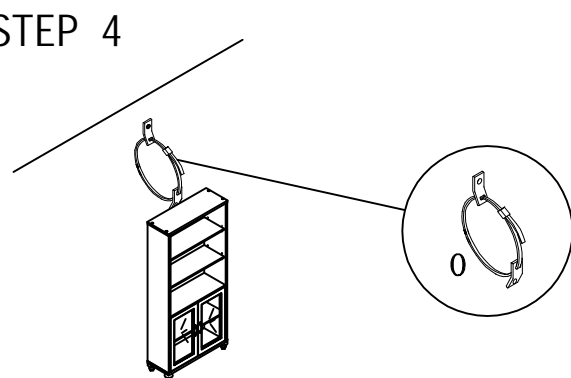

1. Insert strap thru bracket attached to wall, then thru bracket on item, and into head of strap.
 2. pull lightly til strap stops.
- Assembly is complete.