

# ASSEMBLY INSTRUCTION

---

ITEM#: 182314ET

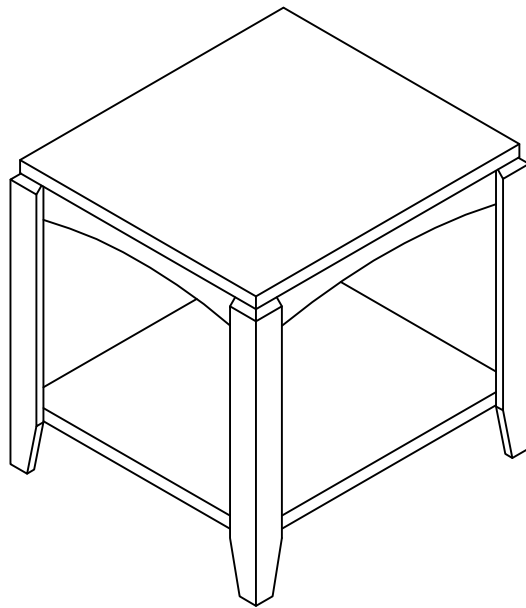

# ASSEMBLY INSTRUCTION

---

## **PLEASE READ BEFORE ASSEMBLING!**

Tip #1: Make sure you've taken all the pieces and hardware out of its packaging before discarding the box. Assembly on top of flattened box/blanket is recommended.

Tip #2: Using page 2 and/or page 3 of instruction manual make sure all pieces and hardware are accounted for.

Tip #3: Note position of all holes on each panel during assembly.

ITEM#: 182314ET

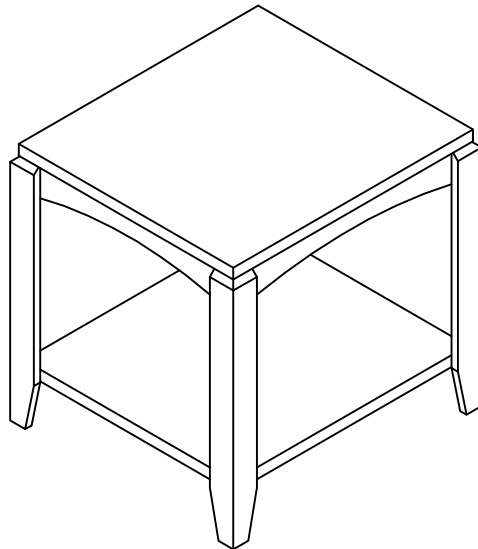

# PARTS IDENTIFICATION

ITEM#: 182314ET

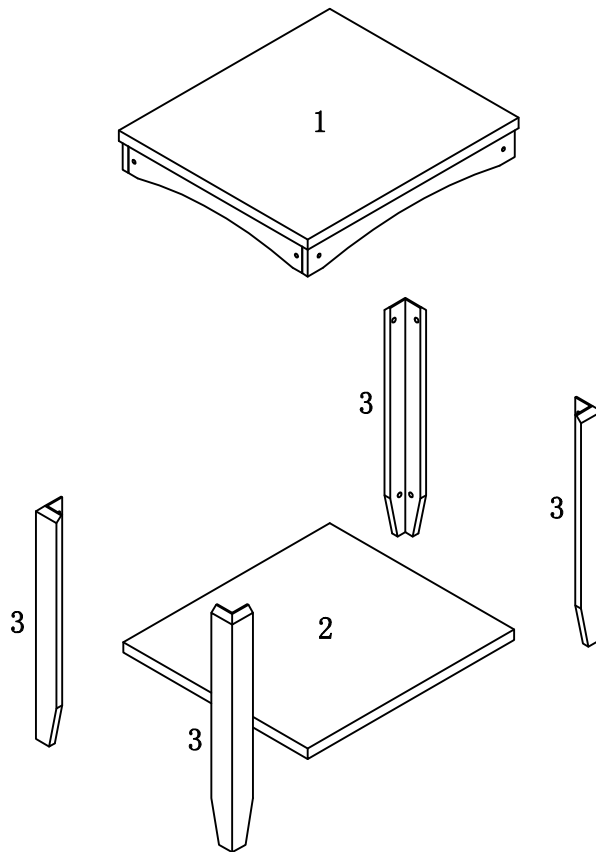

- |     |      |
|-----|------|
| (1) | 1pc  |
| (2) | 1pc  |
| (3) | 4pcs |

# HARDWARE IDENTIFICATION

ITEM#: 182314ET

A  
B  
C



M6x25

8pcs



∅5x25

8pcs





∅16

4pcs

# ASSEMBLY INSTRUCTION

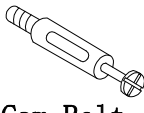
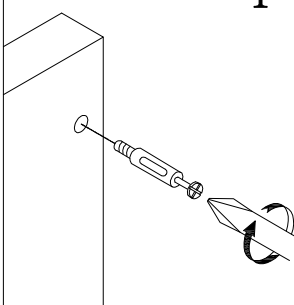
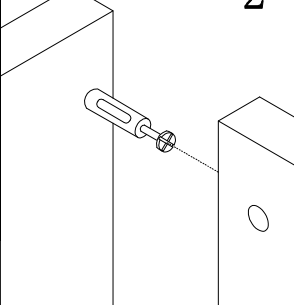
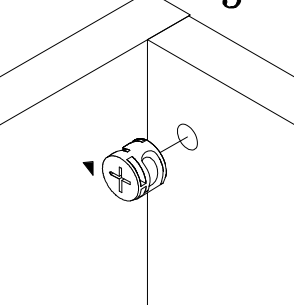
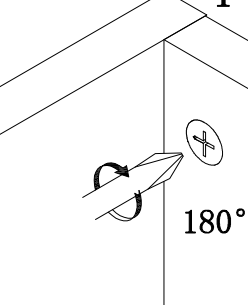
ITEM#: 182314ET

HOW TO	1	2	3	4
 Cam Bolt				
 Cam Lock	1. Screw Cam Bolt into panel.	2. Insert Cam Bolt into bolt hole of joining panel.	3. Insert Cam Lock. arrow facing bolt.	4. Gently turn Cam Lock clockwise to lock position.

## STEP 1

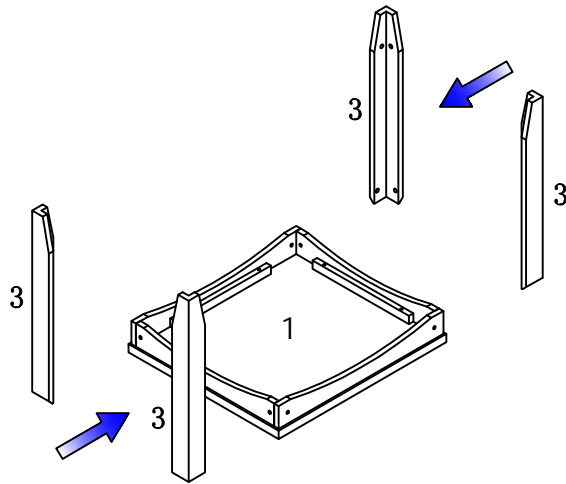

## STEP 2

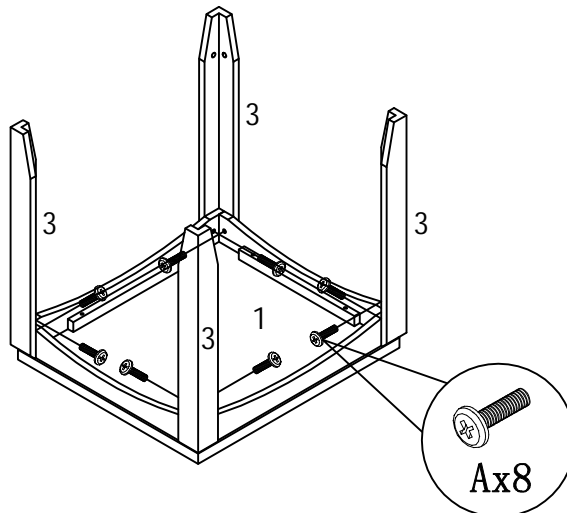

# ASSEMBLY INSTRUCTION

ITEM#: 182314ET

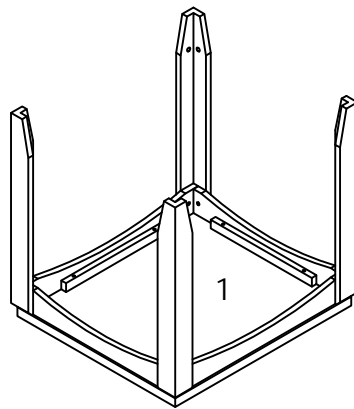
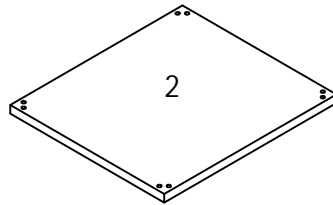

STEP3

STEP4

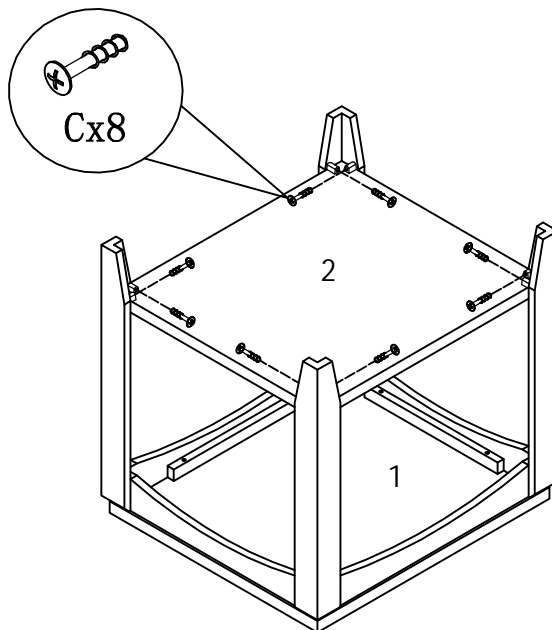

# ASSEMBLY INSTRUCTION

ITEM#: 182314ET

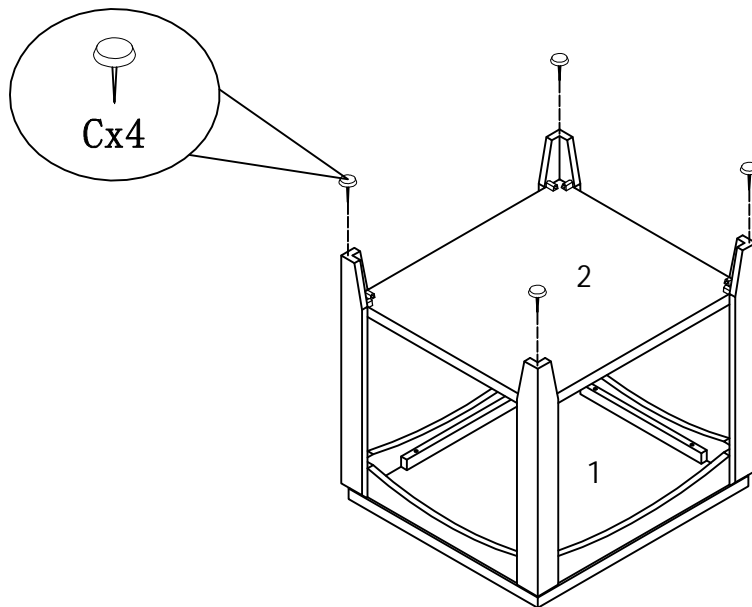

STEP5

STEP6

