

ASSEMBLY INSTRUCTION

PLEASE READ BEFORE ASSEMBLING!

Tip #1: Make sure you've taken all the pieces and hardware out of its packaging before discarding the box.

Tip #2: Using page 2 and/or page 3 of instruction manual make sure all pieces and hardware are accounted for.

Tip #3: Read manual before assembling, it helps!

ITEM#: CB29288-LCH3/CB29288-RC

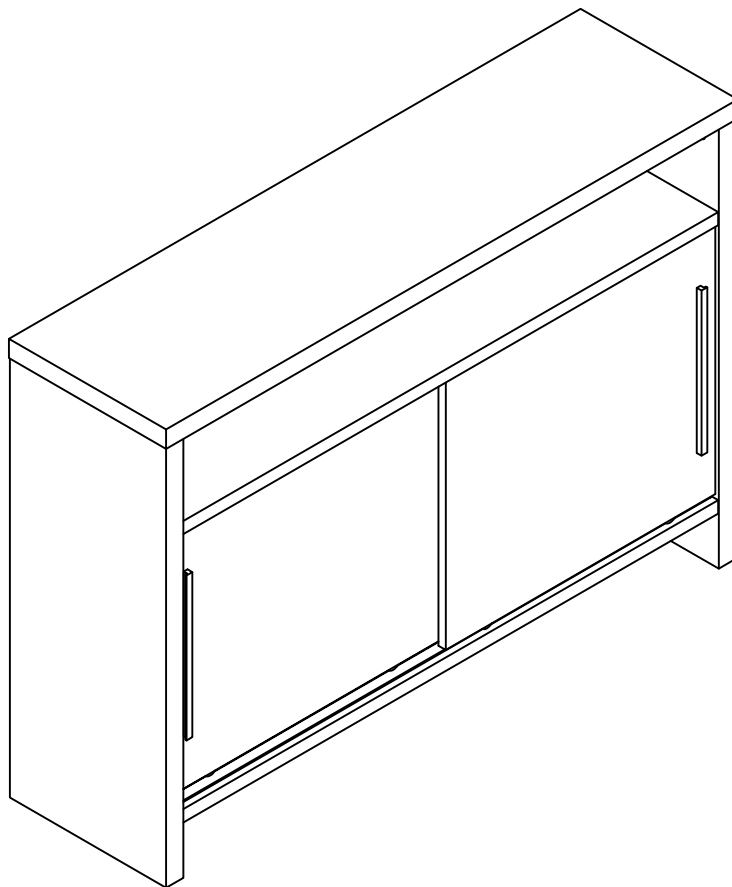

PARTS IDENTIFICATION



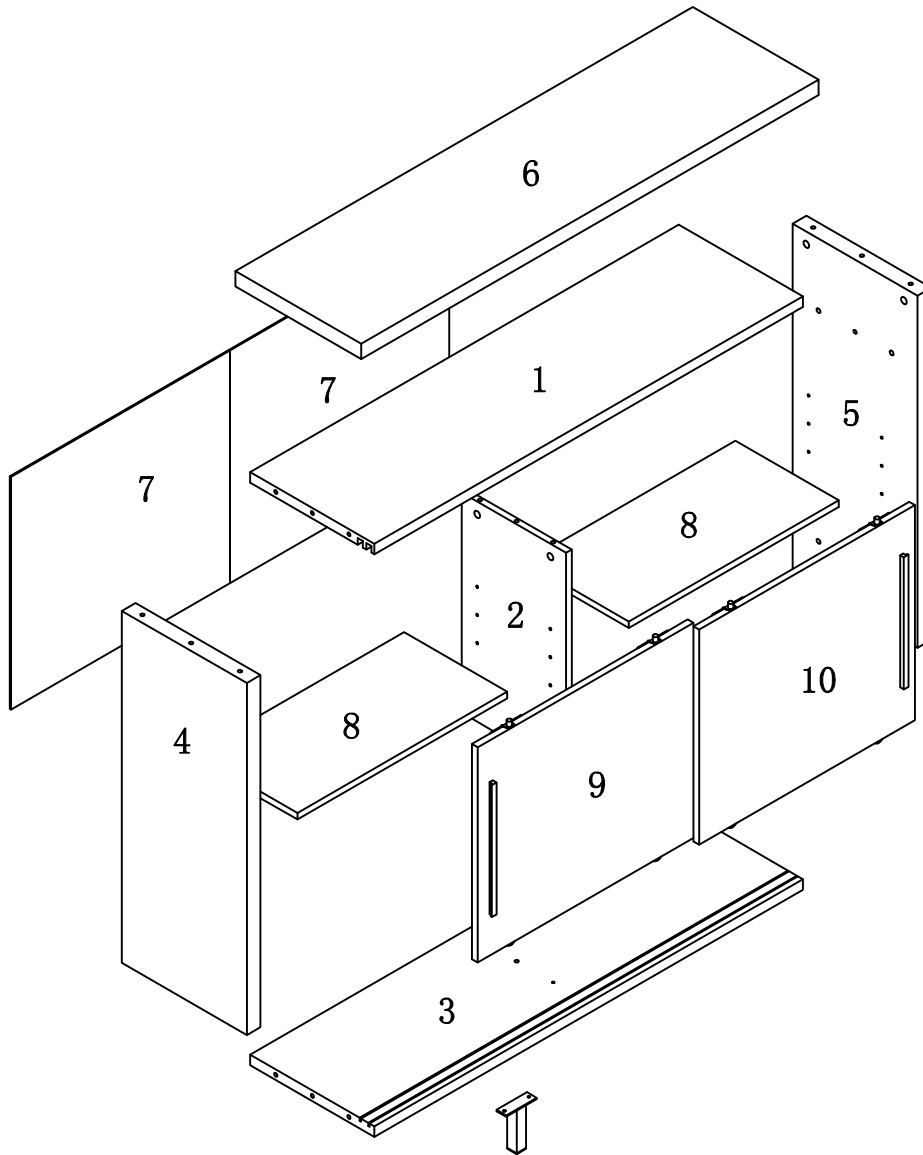









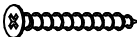

ITEM#: CB29288-LCH3/CB29288-RC

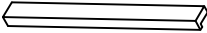

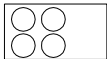
(1)	1pc	(7)	2pcs
(2)	1pc	(8)	2pcs
(3)	1pc	(9)	1pc
(4)	1pc	(10)	1pc
(5)	1pc		
(6)	1pc		

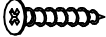
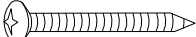
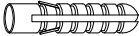
HARDWARE IDENTIFICATION

ITEM#: CB29288-LCH3/CB29288-RC

A		ø8x25	8pcs
B		ø15	14pcs
C		L29	14pcs
D		ø4x40	2pcs
E		ø4x16	2pcs
F			40pcs
G		ø5	8pcs
H		80x25x102	1pc
I		L=300	2pcs
J		ø4x20	4pcs
K		ø18	4pcs
L		ø13	4pcs
M		197×5×1	1pc
N		ø4x25	1pc
O		ø5x40	1pc
P			1pc
S		12×12×1	2pcs
Q		ø16	4pcs
R		Glue: For securing please apply to wood dowel first before inserting into panel	1pc

ASSEMBLY INSTRUCTION

ITEM#: CB29288-LCH3/CB29288-RC

STEP1

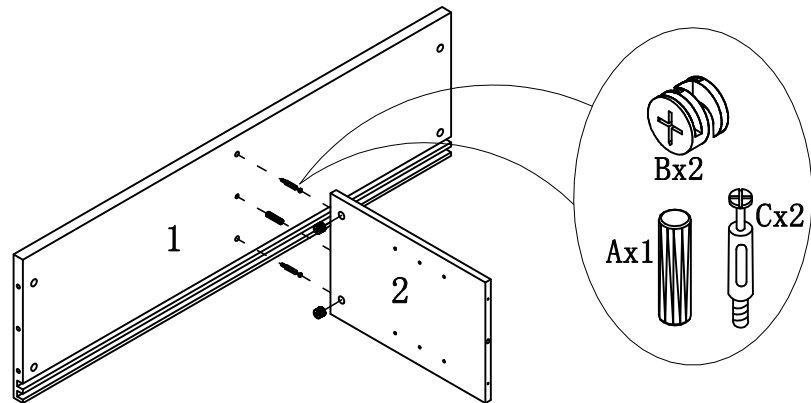

STEP2

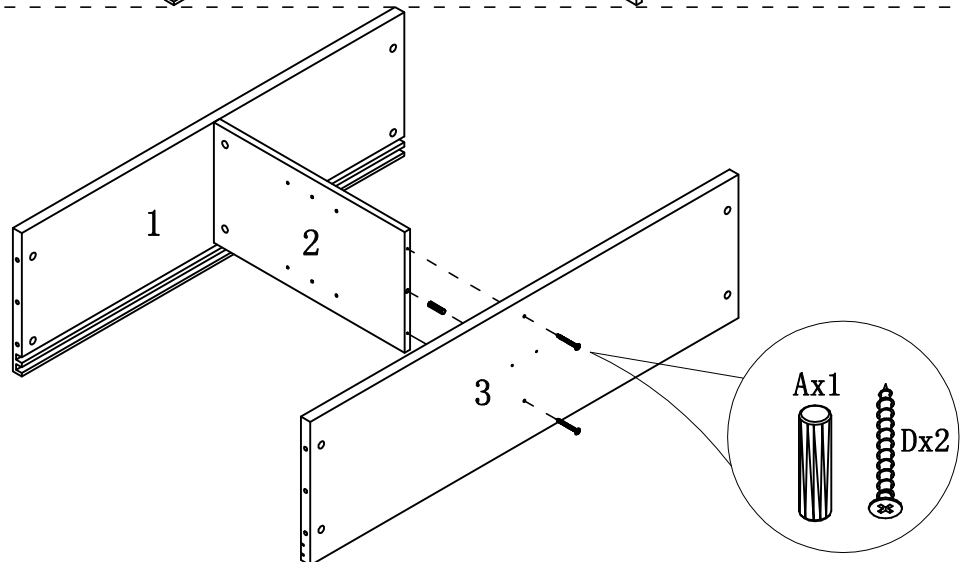

STEP3

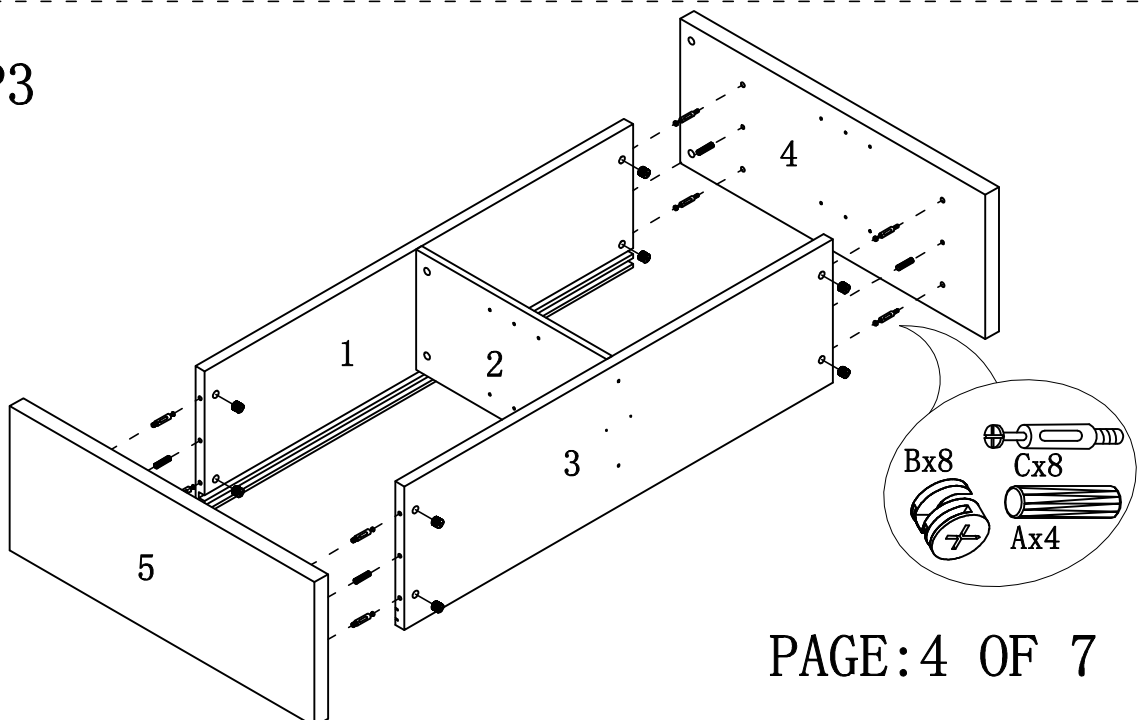

ASSEMBLY INSTRUCTION

ITEM#: CB29288-LCH3/CB29288-RC

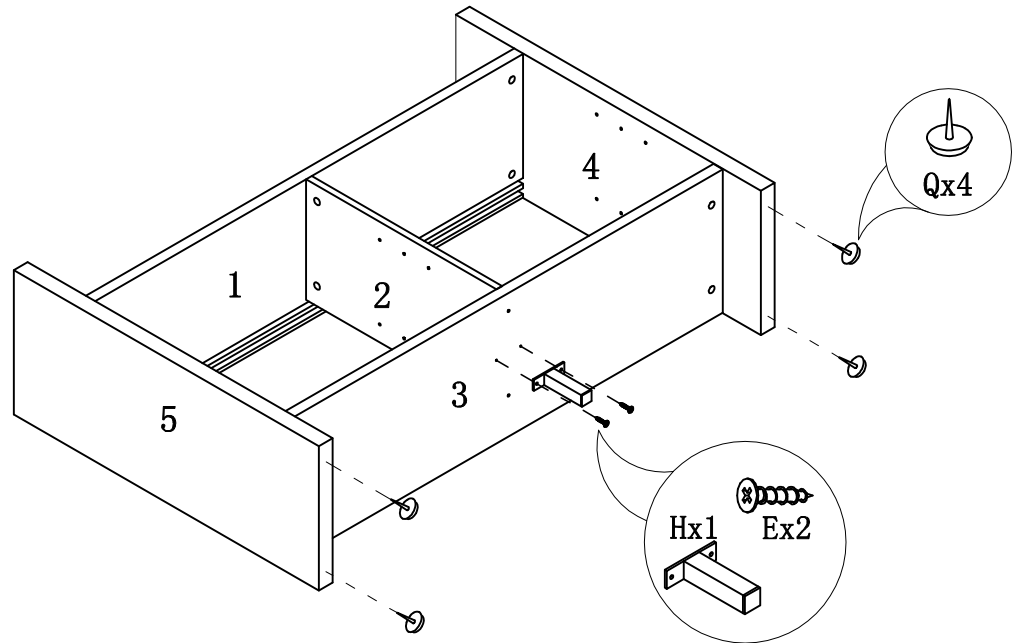

STEP5

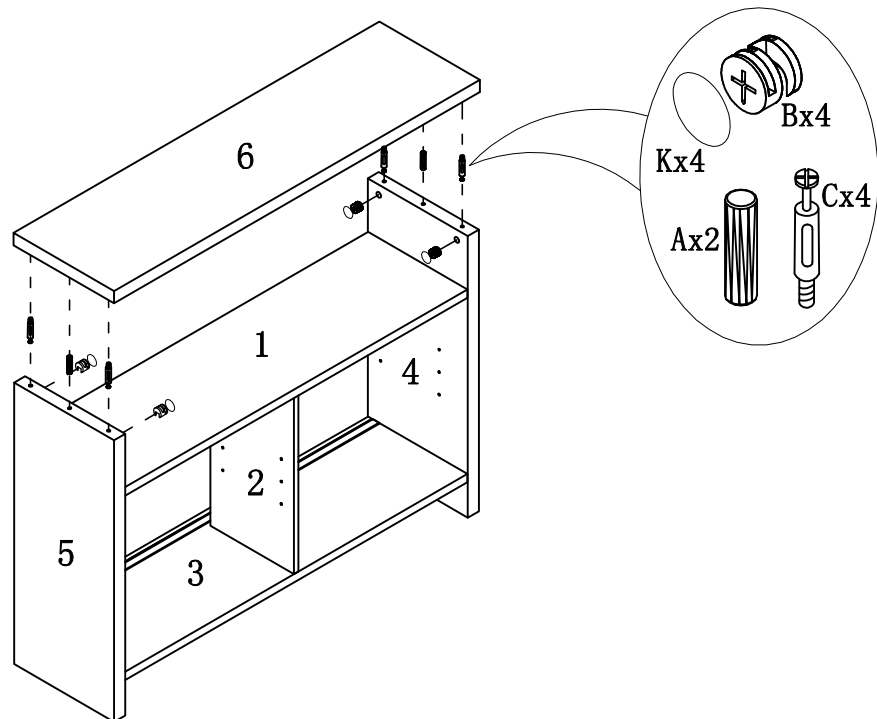

ASSEMBLY INSTRUCTION

ITEM#: CB29288-LCH3/CB29288-RC

STEP6

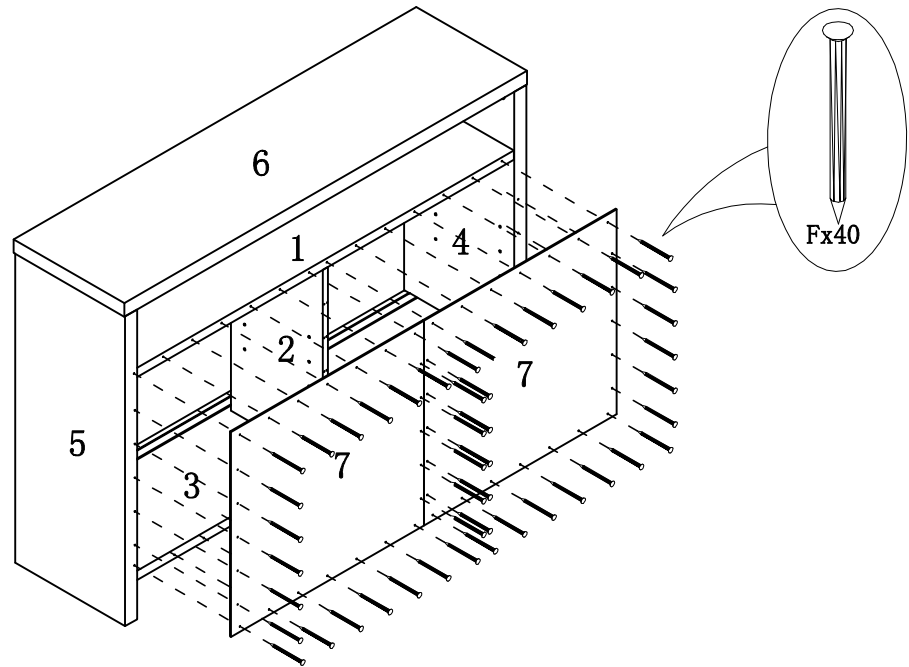

STEP7

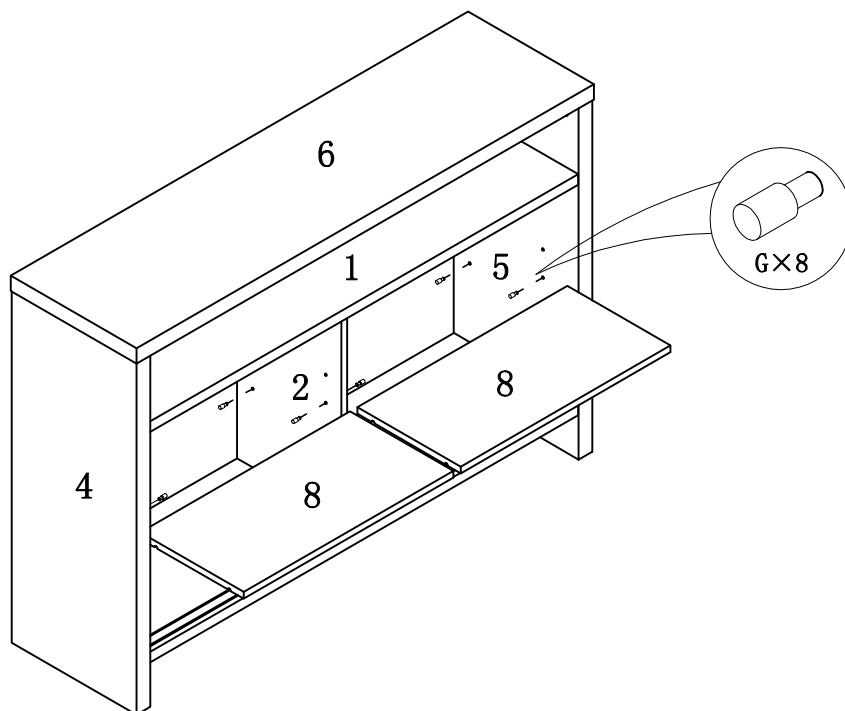

ASSEMBLY INSTRUCTION

ITEM#: CB29288-LCH3/CB29288-RC

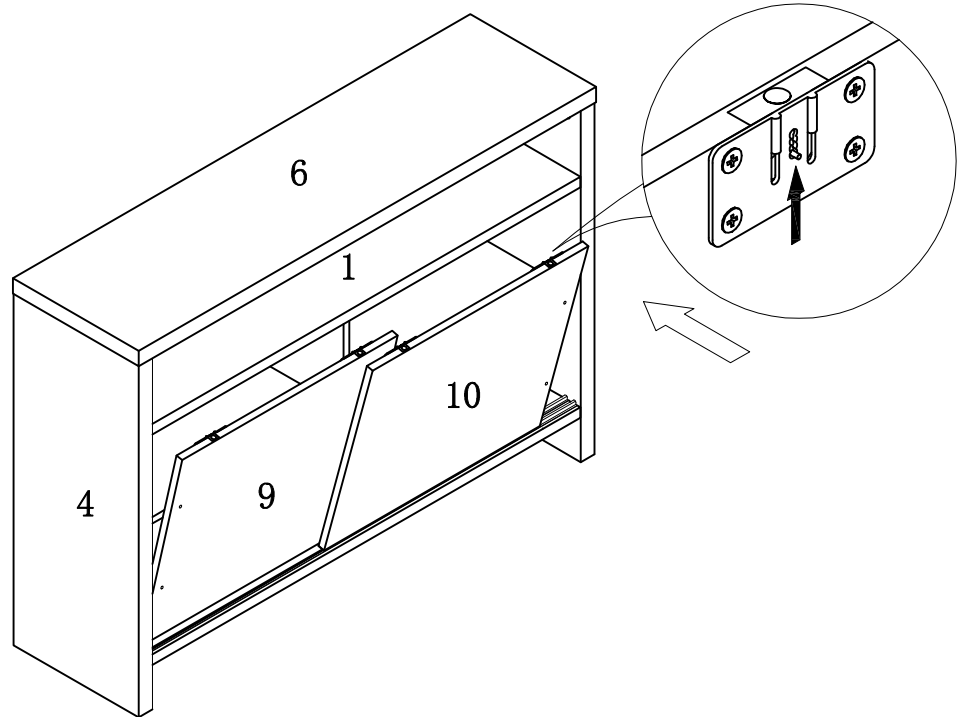

STEP8

STEP9

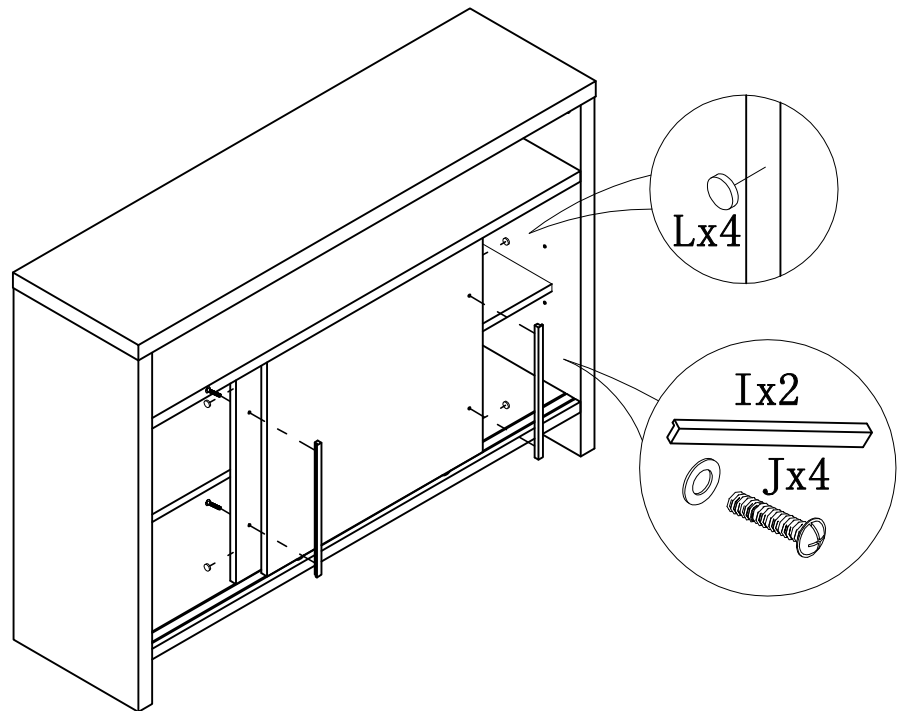

PAGE:7 OF 7

ANTI-TIPPING STRAP INSTRUCTION

HARDWARE (INCLUDED) :

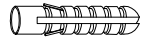

DRYWALL ANCHOR $\phi 8 \times 40$ X 1PC

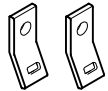

METAL BRACKETS $12 \times 12 \times 1$ X 2PCS

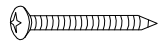

DRYWALL SCREW $\phi 5 \times 40$ X 1PC



STRAP $197 \times 5 \times 1$ X 1PC



FLATHEAD SCREW $\phi 4 \times 25$ X 1PC

TOOLS NEEDED (NOT INCLUDED) :

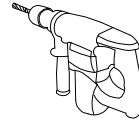

DRILL & DRILL BIT



LIGHT HAMMER

Note: Hardware included only compatible with standard drywalls.

STEP 1

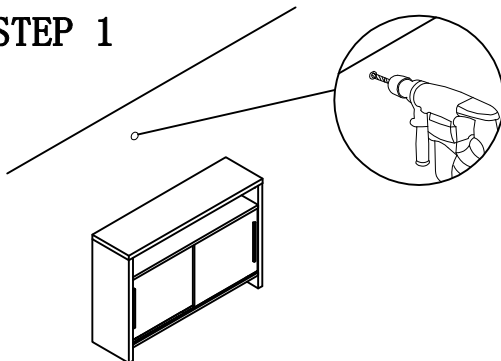

1. Find spot on wall 1" below top of item.
2. Using a drill bit slightly thinner than anchor, drill hole into drywall.

STEP 2

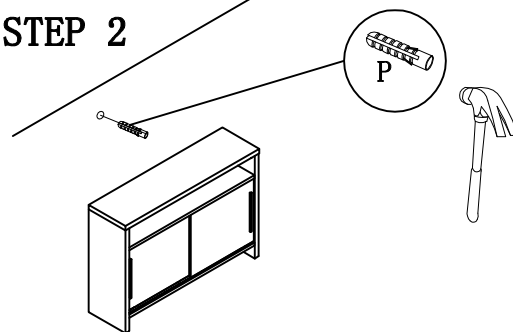

1. Use a light hammer to tap anchor into hole.
2. Anchor should fit snugly. If hole is too small, drill again to increase hole size. Do not force anchor into wall.

STEP 3

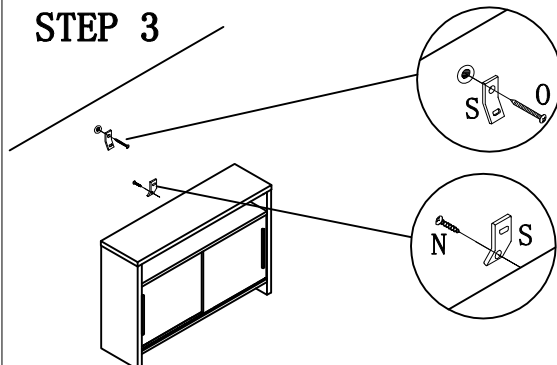

1. Insert drywall screw into metal bracket and into drywall anchor.
2. Insert flathead screw into second metal bracket and into back of item, along top edge.

STEP 4

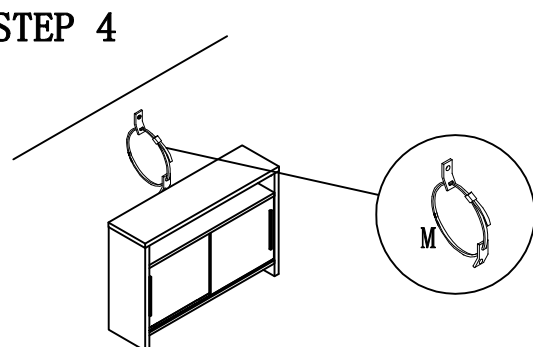

1. Insert strap thru bracket attached to wall, then thru bracket on item, and into head of strap.
 2. pull lightly til strap stops.
- Assembly is complete.